

BLE Submittal Drawing

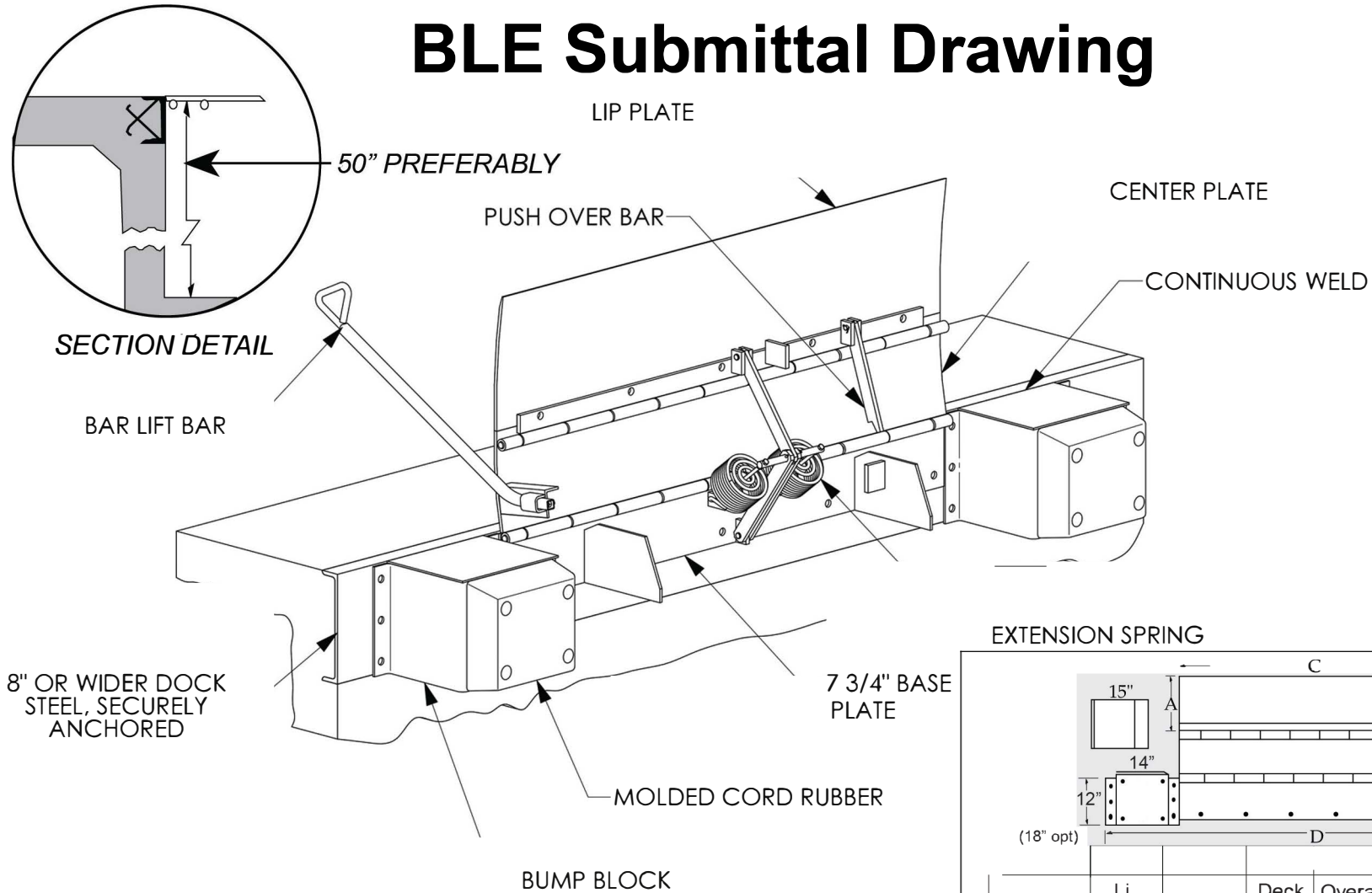

Notes: Deck & Lip - 55,000 min. yield steel

EXTENSION SPRING

The diagram shows an extension spring with dimensions: 15" length, 14" width, 12" height, and 14" height. The overall width is labeled 'C' and the overall length is labeled 'D'. A note '(18" opt)' is present below the diagram.

	Li	Deck	Overall	Rated	Plate	
Model	Len th	S an	Width	Width	Ca acit Lbs.	Thickness
BLE6620	15"	27 3/4"	66"	104"	20 000	3/8"
BLE6625	15"	27 3/4"		104"	25 000	7/16"
BLE6630	15"	27 3/4"	66"	104"	30 000	
BLE7220	15"	27 3/4"	72"	110"	20 000	3/8"

SPECIFY JOB REQUIREMENTS FROM CHART



Perma Tech Inc.
"For ALL Your Loading Dock Needs"

363 Hamburg Street, Buffalo, NY 14204
716-854-0707 • 800-362-7325 •
www.PermaTechInc.com

JOB

Perma Tech Inc. reserves the right to make product improvement at any time without prior notice.